

TREBLE R FABRICATIONS

UNIT 42 – CROSSGATE ROAD – PARK FARM INDUSTRIAL ESTATE – REDDITCH – WORCS – B987SN

tel 01527 503 303 – fax 01527 503 325 – web www.treblefabrications.co.uk

RECTANGULAR/SQUARE FLAP VALVES

STEEL FRAME AND HDPE DOOR

The primary application of flap valves is for surface water drainage associated with rivers, estuaries and sea water outfalls to prevent reverse flow conditions. Flap valves can be utilised on final effluent outfalls for sewage treatment plant to prevent flood damage within the works.

The flap valves should be positioned on the outfall structure to avoid the build-up of debris around the invert area which could prevent the valve operating correctly. Sufficient ‘fall away’ should be provided between the invert of the flap valve and the base of the outfall structure.

Flap valve application on sea water outfalls should be given careful consideration due to turbulence of flow across the flap, particularly when severe wave action is involved, resulting in dislocation of the flap relative to the seats. Wherever possible the flap valve should be located in a shielded position to minimise the effects of severe wave action.



In many cases the end user preference is a heavy duty door with a mechanical hinge to give maximum flow. The steel frame and HDPE door therefore satisfy this requirement giving a reasonable cracking head and low head loss through the flap itself, during operation. Subject to the clients needs and environmental conditions the selection of material can be mixed. Materials available for this design is galvanised mild steel, painted mild steel and 304 / 316 grade stainless steel for the outer frame complete with a heavy duty HDPE door.

RECTANGULAR FLAP VALVES

Rectangular/Square Flap Valves **Steel Frame & HDPE Door**

Operating Duty

Application:	Prevents reverse flow
Type of Mounting:	Wall
Type of Media:	Water and Sewage
Operating Head:	6 Metres on-seating

Options

Design Heads:	Higher head designs available
Size Range:	Any size from 400mm to 2000mm in square or rectangular format
Extra's	Counter balanced doors

Construction Materials

<u>ITEM</u>	<u>DESCRIPTION</u>	<u>MATERIAL</u>
1	Frame	Mild Steel, BS 4360 Gr 43A Stainless Steel, BS 970 Gr 304 Stainless Steel, BS 970 Gr 316
2	Door	HDPE
3	Seals	Neoprene
4	Hinge Pins	Stainless Steel, BS 970 Gr 316
5	Fasteners	Stainless Steel, BS 6105, Gr A4

Rectangular/Square Flap Valves Steel Frame & HDPE Door

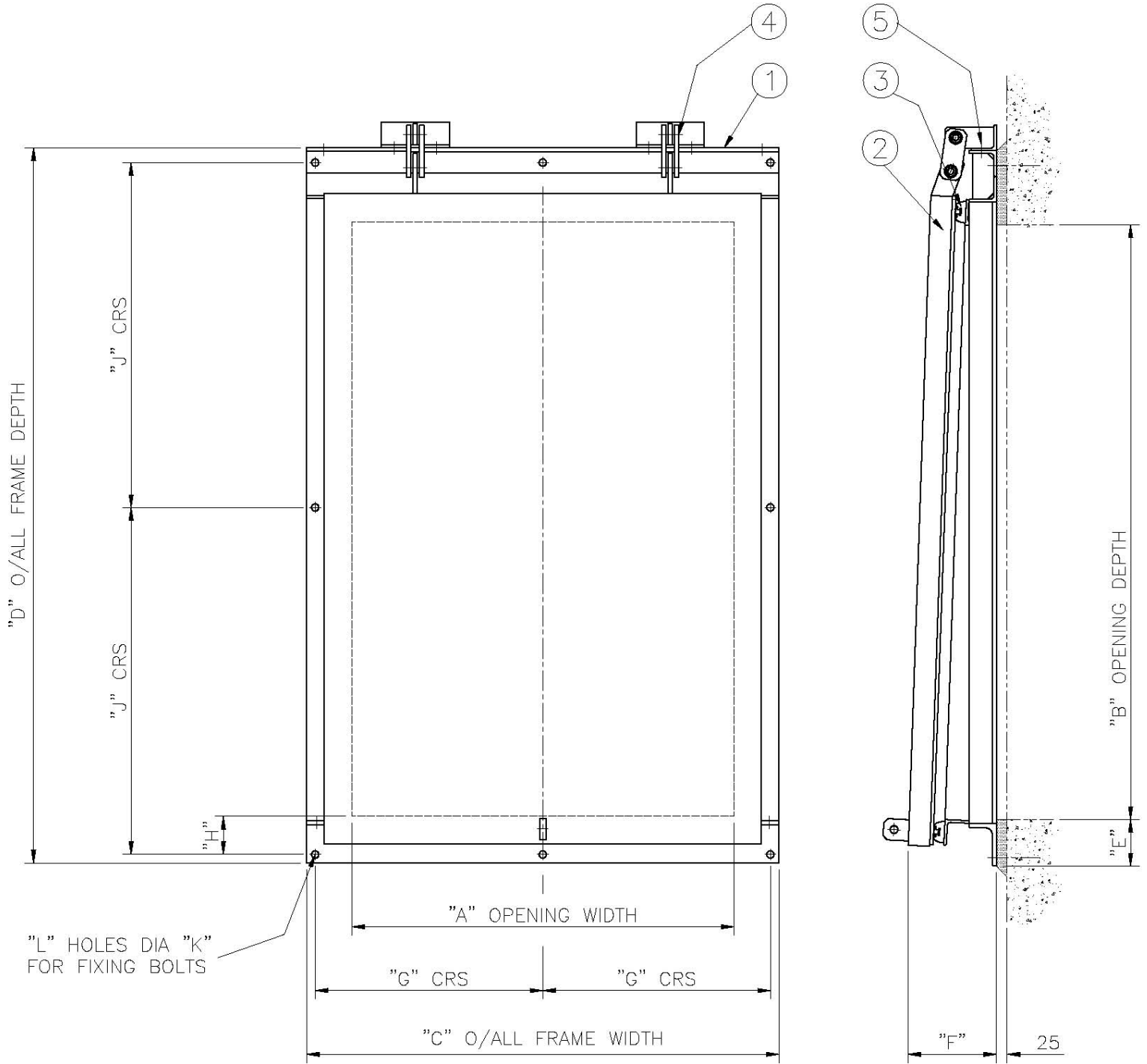

Rectangular/Square Flap Valves
Steel Frame & HDPE Door

Dimensions : See Dimensional Drawing

Range	Small	Medium	Large
A	Width	Width	Width
B	Depth	Depth	Depth
C	A + 212	A + 270	A + 320
D	B + 295	B + 352	B + 377
E	100	125	150
F	270	275	320
G/J	SUBJECT TO SIZE SELECTION		
H	80	95	120
K	17	17	17
L	8	12	16

LOSS OF HEAD THROUGH FLAP GATES

Test conducted on flap gates show that the loss of head due to the flap riding on the water is very small compared with other losses in the hydraulic structure. Of course the entrance loss is usually considerably more critical than loss at the flap gate on the outlet end of conduit.

The hydraulic laboratory of the State University of Iowa conducted a series of test some years ago to determine the amount of head lost by water discharging through rectangular Flap Gates (Model 10C). The gates 16, 24 and 30 inches in diameter were supplied from commercial stock.

The following passage is excerpted from the report of Professor Floyd A. Nagler, associate professor of Mechanics and Hydraulics, who supervised the investigation.

Based on these experiments the following empirical formula was derived to express the loss in head through rectangular gates of varying sizes and with different velocities of flow.

L - Loss of head in feet

V - Velocity of flow through gate in feet per second

D - Diameter of outlet in feet

E - Base of natural logarithms.(2.7183)

$$L = \frac{4V^2}{G} \times E \left[\frac{-1.15V}{\oplus D} \right]$$

It may be concluded from these experiments that the rectangular gate in its hydraulic characteristics is all that the manufacturers have claimed for it. The small loss in head obtained through these gates demonstrates that their installation has but little effect on the discharged capacity of drainage outlets.

Medium and heavy duty flap gates have heavier flaps or covers than the gate model tested. As a result, head losses through these gates may be slightly more than those indicated by the test.

LOSS OF HEAD THROUGH FLAP GATES

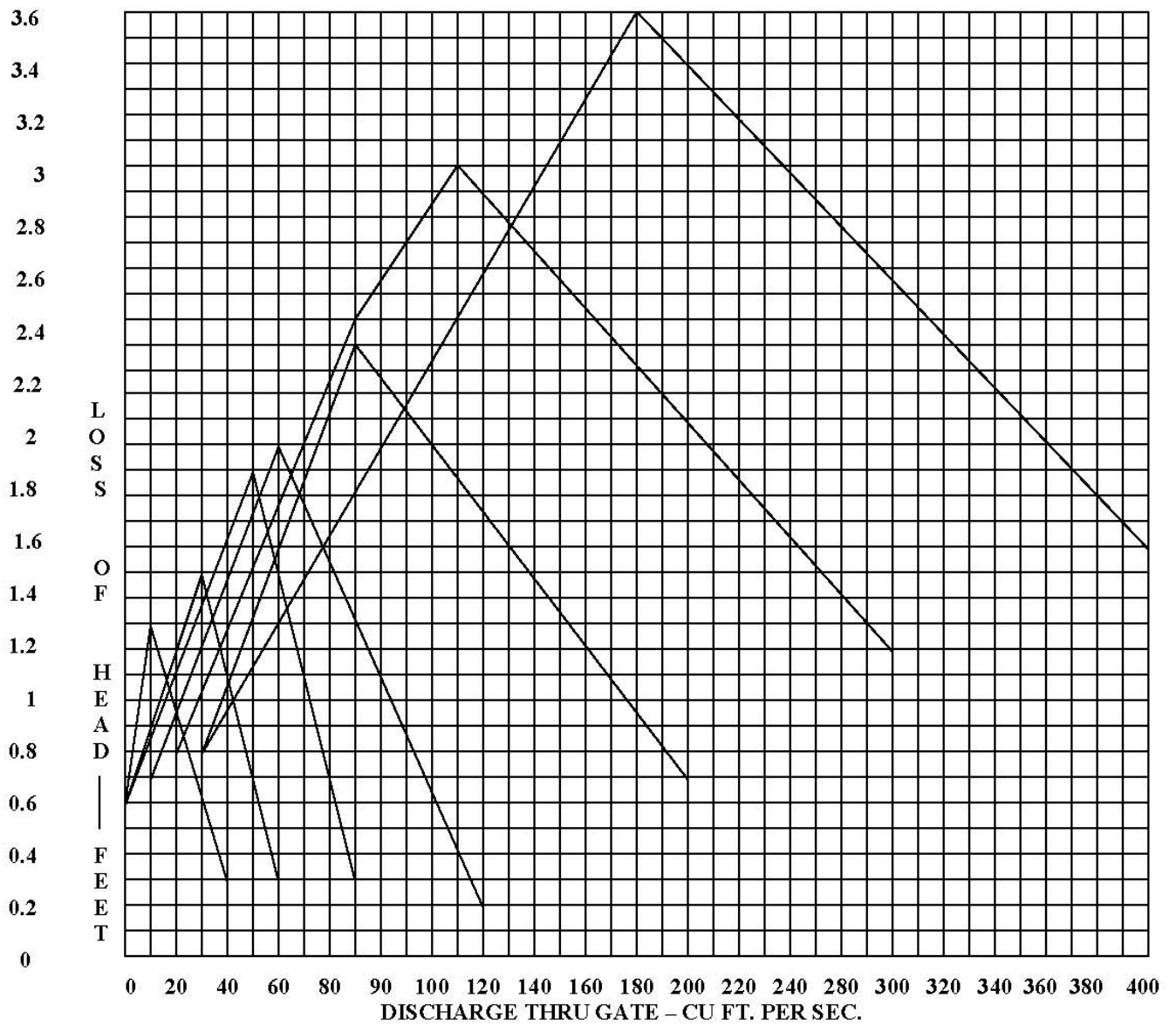
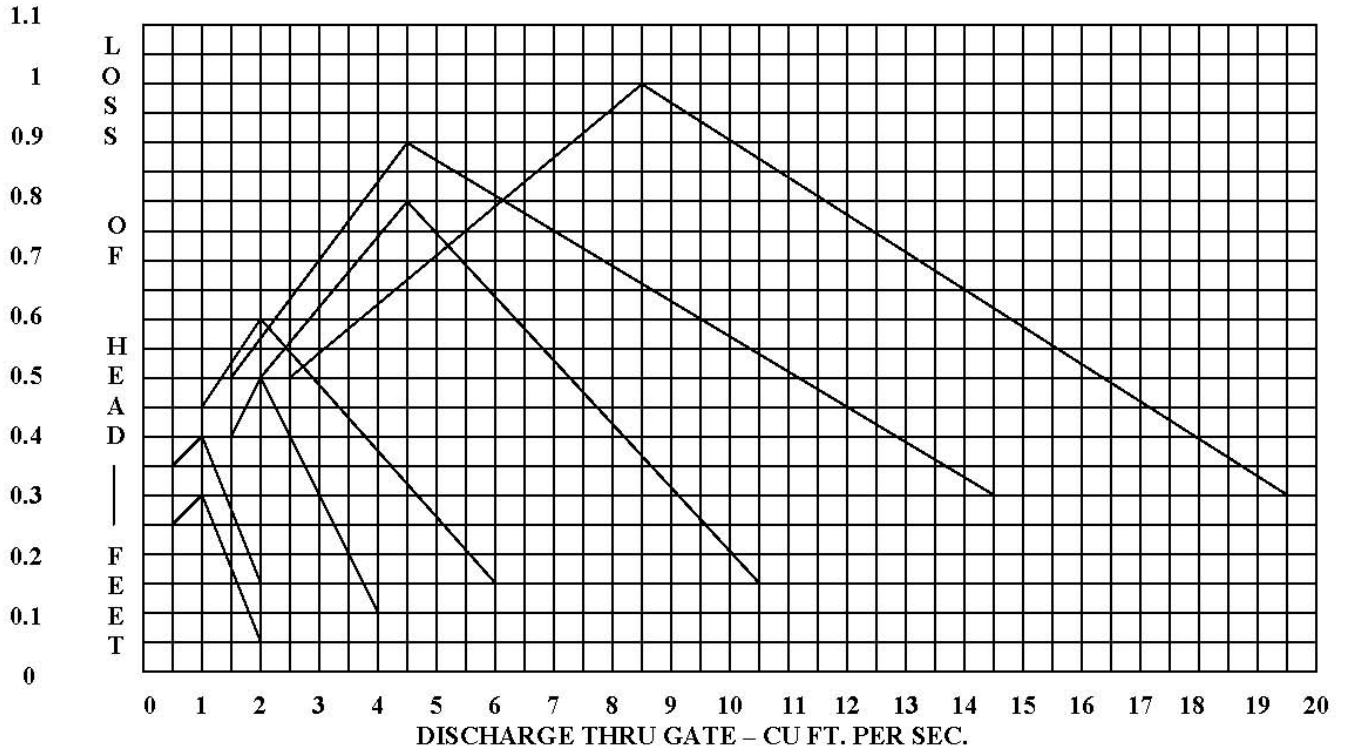

Rectangular/Square Flap Valves
Steel Frame & HDPE Door
Cracking Head and Head Loss Chart

WIDTH	DEPTH	CRACKING HEAD(mm)	HEAD LOSS(mm)
500	500	31	95
600	600	56	103
700	700	64	110
800	800	69	113
900	900	73	115
1000	1000	90	127
1100	1100	93	130
1200	1200	96	132
1300	1300	98	134
1400	1400	99	135
1500	1500	101	136
1600	1600	109	141
1700	1700	119	148
1800	1800	126	153
1900	1900	133	158
2000	2000	138	162

RECTANGULAR FLAP VALVE STEEL FRAME AND HDPE DOOR

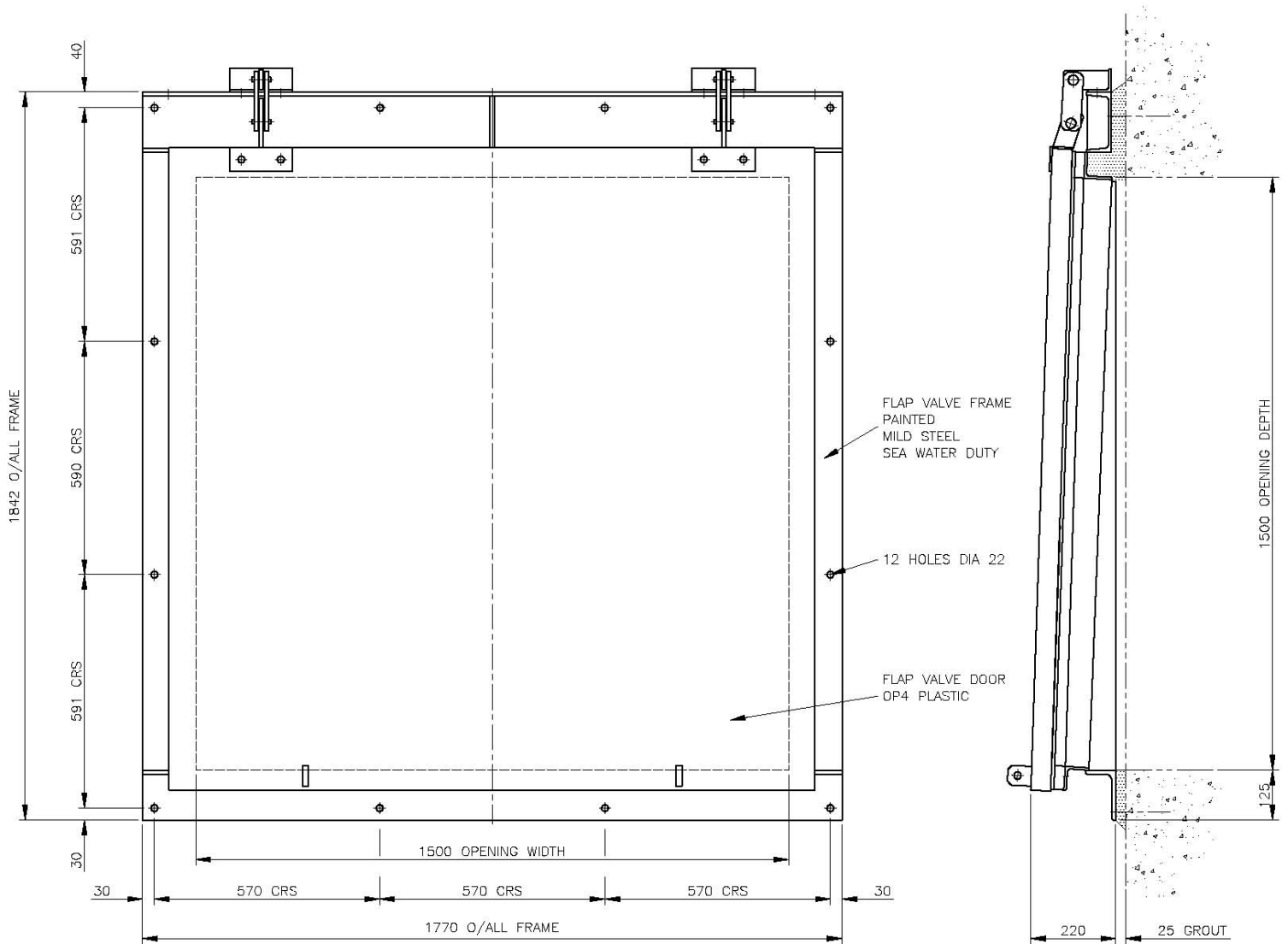

**Typical Drawing only of a Rectangular
Fabricated Flap Valve.
Painted Mild Steel Frame and HDPE Door.
Size 1500 x 1500**